

DIAMETER GRADER CALDI 58 ZP



M

Machinery manufactured in stainless steel following the best quality standards, providing the best finish and resistance.

M

More than 80 types of machines for processing all types of vegetables such as potatoes, carrots and fruit, unique design. Do not settle for mere copies.

A

Aadjustable in length, width and height with numerous sizes and designs to always provide the right solution to your needs.

Q

Quality, design and efficiency in all our machines to extend their working life and make your work as easy as possible.



The **MARTIN MAQ Diameter Grader CALDI 58 ZP** is a grader with turning rollers perfect to size the product with a capacity of up to 8 t/h. It is adequate for carrots, parsnips, onions, different varieties of potatoes, turnips, lemons and oranges, etc. Built entirely in stainless steel, it has great resistance and it is very easy to clean and maintain. It can grade 4 to 5 sizes with great precision. It can be adjusted manually or by an electric device.



IMPORTANT PARTS OF THE MACHINE

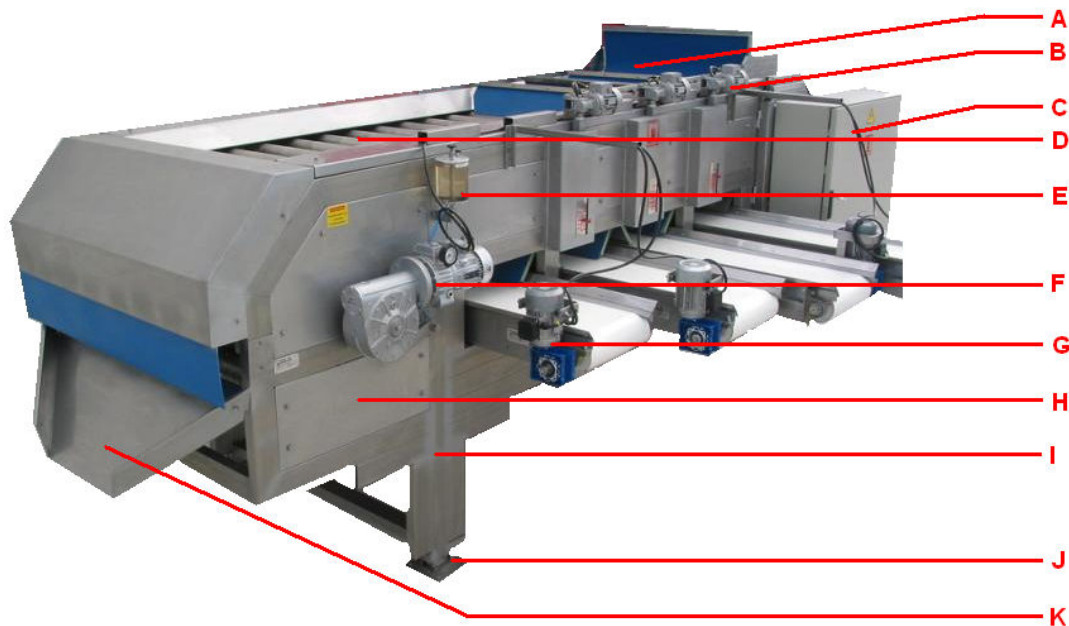

A: Product protection band.

B: Motors to adjust grades, from which the diameters from the 4 or 5 grades can be selected (depending on need).

C: Electrical board (optional).

D: Stainless steel rollers, in two sizes to improve grading.

E: Chain lubrication deposits.

F: Rollers operated with motor and speed adjuster. High resistance chain transmission.

G: Exit conveyor. A conveyor for each size is need and will be made to the length required by the customer for each size. These conveyors are not included when purchasing the grader.

H: Inspection and cleaning lock-gates.

I: Robust, built in stainless steel.

J: Adjustable legs.

K: Product exit, larger, for last size or waste.

TECHNICAL SPECIFICATION

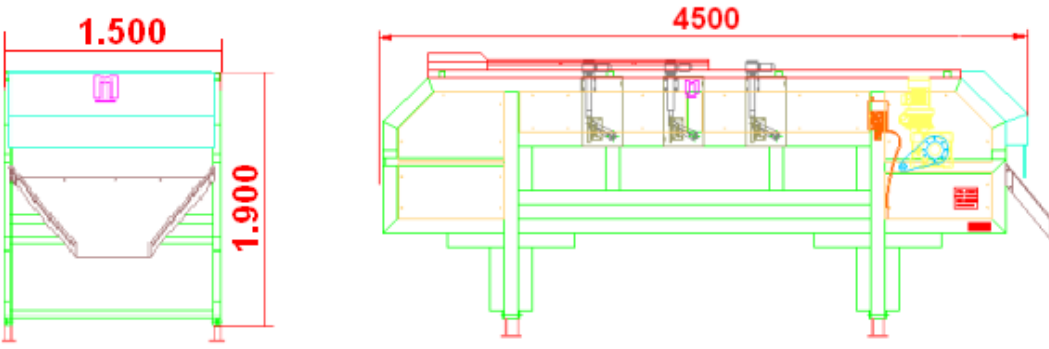
DIAMETER GRADER CALDI 58 ZP	Length: 4.500 mm Width: 1.500 mm Height: 1.900 mm (+ legs)
	

- Grading by rollers with high resistance chain transmission.
- Grades: 4 to 5 sizes (all sizes leave the machine via conveyors, including the last one and the largest one)
- Manual grading system. Electric system optional.
- Robust, built entirely in stainless steel.
- Product protection band.
- Process controlled by speed adjuster.
- Output: Up to 10 T/h.
- Valid for carrots, parsnips, onions, potatoes, lemons, oranges, etc.
- Weight: 2.500 Kg (depending on model and options).
- Two chain self-lubricating deposits.
- Easy access to mechanisms.
- Product protected with rubber bands (when leaving conveyors)
- Special track for chain support (extends the chain's working life)
- Chain with electronic speed adjuster
- Electric board (optional)
- CE Marking
- **NEW:** Controlled speed, to avoid damage to the rollers in case of an instant stopping action caused by an overload of product.

At **MARTIN MAQ** we know that you take great care of your product.

We know that this requires much effort and dedication. This is why we always place all our efforts in designing and manufacturing machines that will help you process your product efficiently, giving it the best possible finish.

We build all our machines to the highest of quality standards, making maintenance very easy and extending the machine's working life.

We have, at your disposal, an after-sales technical team that will assist you with any doubts that you may have during use and will inform you about how to care for your machine and keep maintenance as low as possible.

AFTER-SALES SERVICE

**ALWAYS REQUEST
ORIGINAL
MARTIN MAQ
SPARE PARTS**



I+D+I



FABRICACIÓN

**SERVICIO
POST VENTA**



REPUESTOS



MARTIN MAQ

Autovía A-601, Exit 91
40291 TABANERA LA LUENGA
Segovia (SPAIN)

T: +34-921-122 122
F: +34-921-57 70 88
e-mail: martinmaq@martinmaq.com
www.martinmaq.com

MARTIN MAQ Distributor:

