



MARTIN MAQ[®]

MAQUINARIA HORTICOLA
VEGETABLE HANDLING SYSTEMS

CYCLONIC STONE REMOVER QP 20 C40



M

Machinery manufactured in stainless steel following the best quality standards, providing the best finish and resistance.

M

More than 80 types of machines for processing all types of vegetables such as potatoes, carrots and fruit, unique design. Do not settle for mere copies.

A

Aadjustable in length, width and height with numerous sizes and designs to always provide the right solution to your needs.

Q

Quality, design and efficiency in all our machines to extend their working life and make your work as easy as possible.

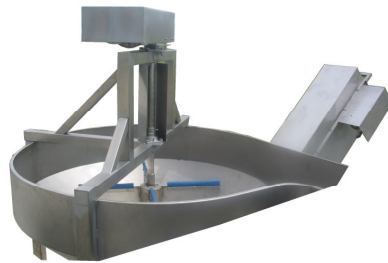

The **MARTIN MAQ Stone Remover QP20 C40** has been designed to remove all stones when they come from the field with a product, such as carrots, potatoes, etc.

Extremely efficient with a capacity of up to 20 t/h.

Built totally in stainless steel.
Very low maintenance.
Water consumption is also very low.



IMPORTANT PARTS OF THE MACHINE

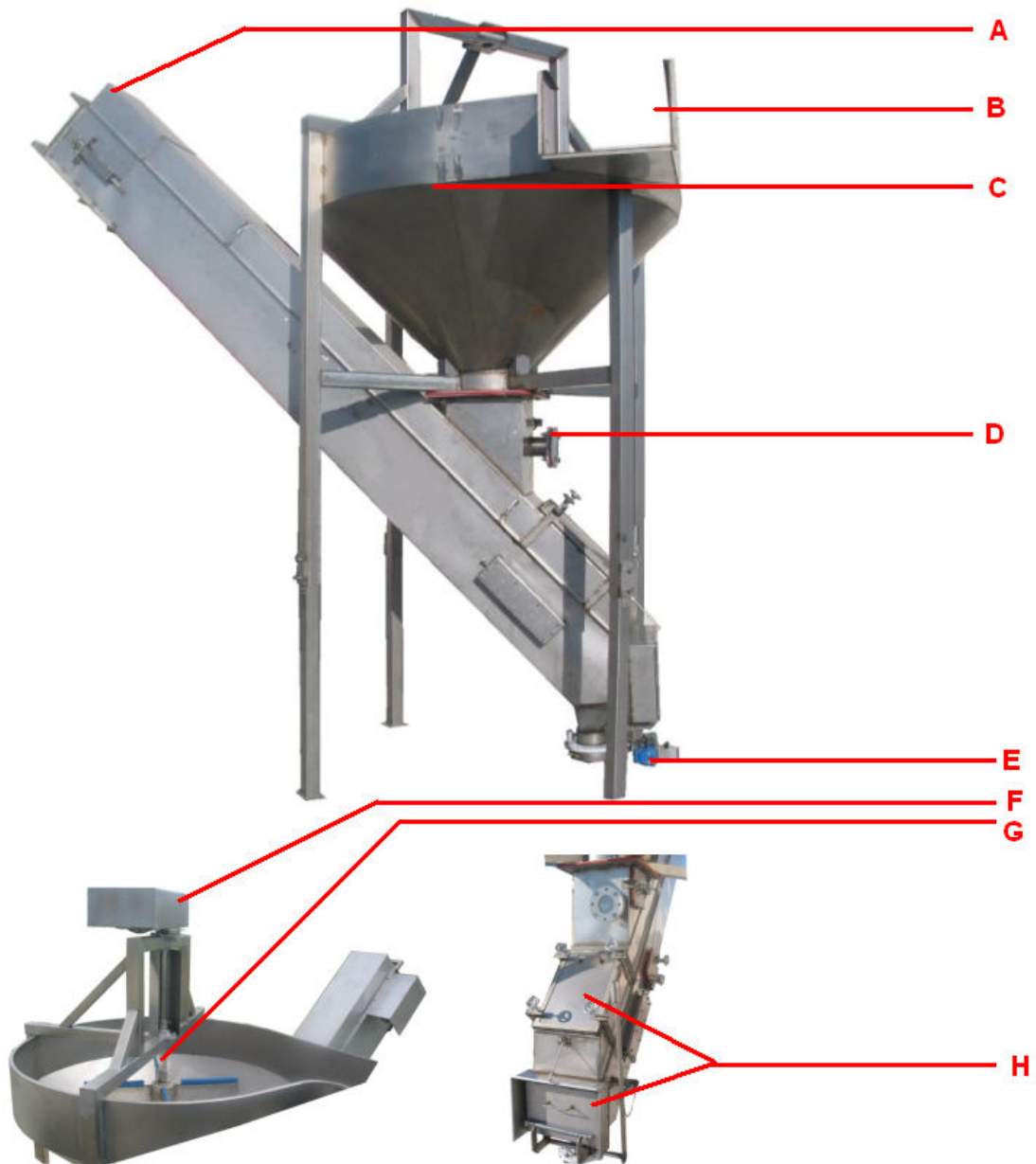

A: Stone exit conveyor size 4.000 mm.

B: Exit opening - size: 506 mm (product).

C: 2 m diameter deposit in a cone shape.

D: Water entry. This water comes from a pump specially designed for this stone remover (included).

E: Mud and water exit valve.

F: Motor to spin/stir the blades protected (should the machine work outdoors)

G: Four blade stirrer.

H: Access and cleaning lock-gates.

TECHNICAL SPECIFICATIONS

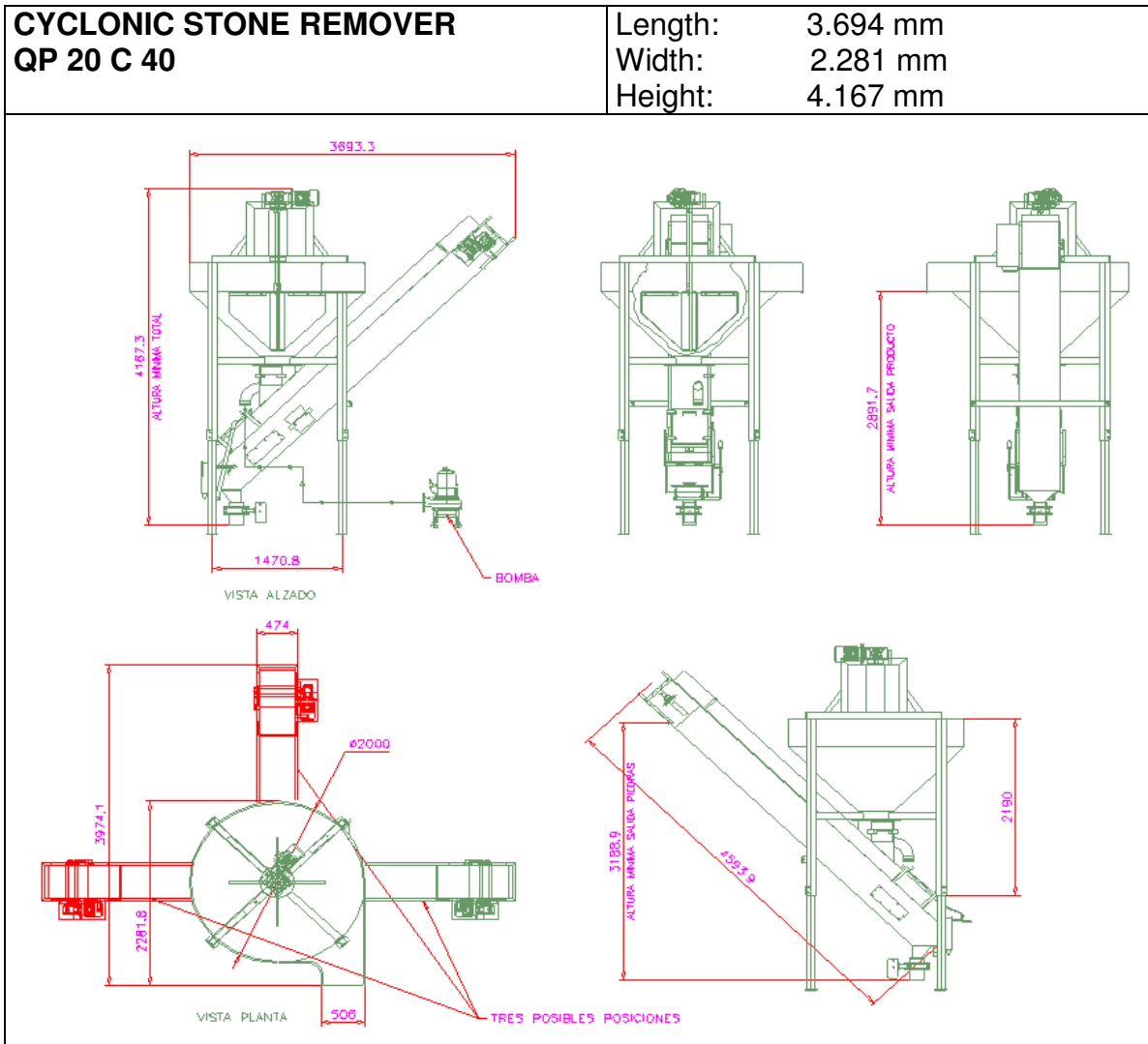

- Robust, built entirely in stainless steel.
- The conveyor and blades are removable to make transport easy.
- Adjustable height.
- Stone exit enlarged to prevent stones becoming stuck.
- Elimination of accumulated mud by pneumatic timed valve.
- Very low maintenance.
- Specially designed lock-gates on machine's "blind-spots".
- Constant stirring / spinning speed.
- Blades designed to not harm the product.
- Rubber stone extraction conveyor.
- Underwater re-circulation pump (not adjusted to the machine)
- Special motors so the machine can be placed outdoors.
- Electric board (optional).
- Capacity: up to 20 t/h.
- Water consumption: between 1 and 2 m3 per hour.
- Power: 6.9 Kw, including the water pump.
- CE Marking.
- Adequate for carrots, potatoes, turnips, parsnips ...

At **MARTIN MAQ** we know that you take great care of your product.

We know that this requires much effort and dedication. This is why we always place all our efforts in designing and manufacturing machines that will help you process your product efficiently, giving it the best possible finish.

We build all our machines to the highest of quality standards, making maintenance very easy and extending the machine's working life.

We have, at your disposal, an after-sales technical team that will assist you with any doubts that you may have during use and will inform you about how to care for your machine and keep maintenance as low as possible.

AFTER-SALES SERVICE

**ALWAYS REQUEST
ORIGINAL
MARTIN MAQ
SPARE PARTS**



I+D+I



FABRICACIÓN

**SERVICIO
POST VENTA**



REPUESTOS



MARTIN MAQ
Autovía A-601, Exit 91
40291 TABANERA LA LUENGA
Segovia (SPAIN)

T: +34-921-122 122
F: +34-921-57 70 88
e-mail: martinmaq@martinmaq.com
www.martinmaq.com

MARTIN MAQ Distributor:

