



MARTIN MAQ[®]

MAQUINARIA HORTICOLA
VEGETABLE HANDLING SYSTEMS

DOUBLE BOX FILLER LOS 640



M

Machinery manufactured in stainless steel following the best quality standards, providing the best finish and resistance.

M

More than 80 types of machines for processing all types of vegetables such as potatoes, carrots and fruit, unique design. Do not settle for mere copies.

A

Aadjustable in length, width and height with numerous sizes and designs to always provide the right solution to your needs.

Q

Quality, design and efficiency in all our machines to extend their working life and make your work as easy as possible.



The **MARTIN MAQ Double Box Filler** is the right machine to fill boxes automatically without stopping, as this system allows you to change and replace an empty box, while the one next to it is being filled.

It is adequate for potatoes, turnips, etc. and has a capacity between 15 and 20 t/h.

Made of stainless steel with PVC belt.

Protection "cover" for when the product falls into the box.



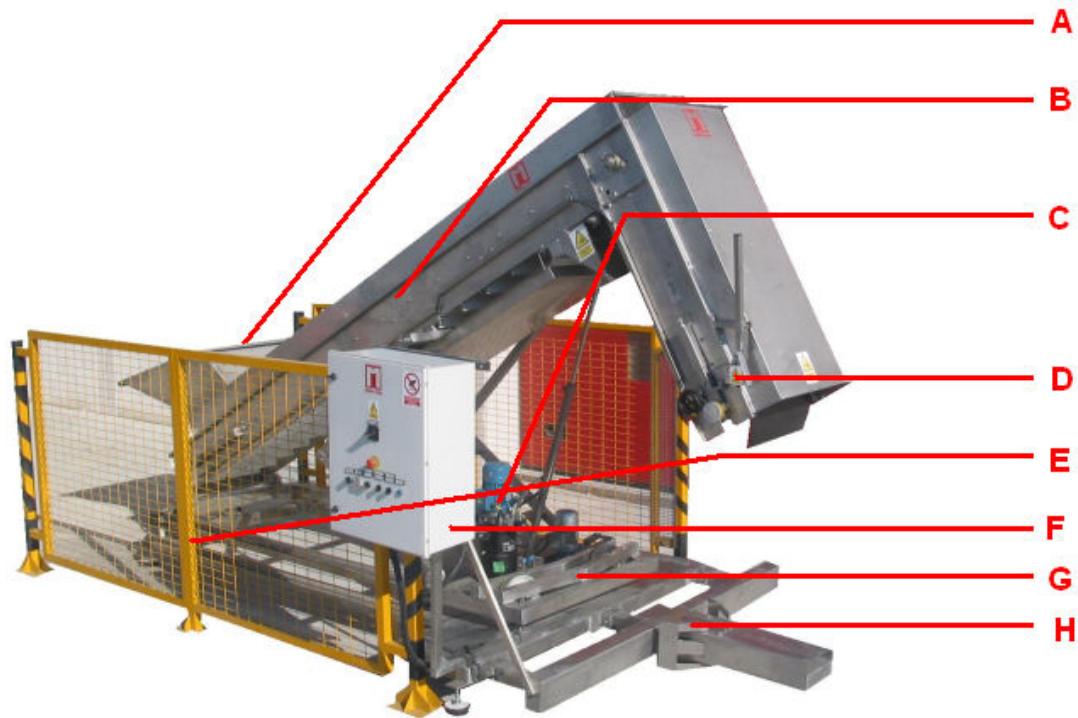

- A:** Reception hopper padded to protect product.
- B:** Elevating conveyor made of PVC totally covered to avoid dirt falling during movement.
- C:** Hydraulic system to rise and lower the conveyor when filling the boxes.
- D:** Product detector that allows a continuous filling of the boxes.
- E:** Security fences that follow all safety regulations.
- F:** Electric board.
- G:** Mobile platform that makes possible the correct filling of boxes alternatively.
- H:** Platform support and detection of boxes.

TECHNICAL SPECIFICATIONS

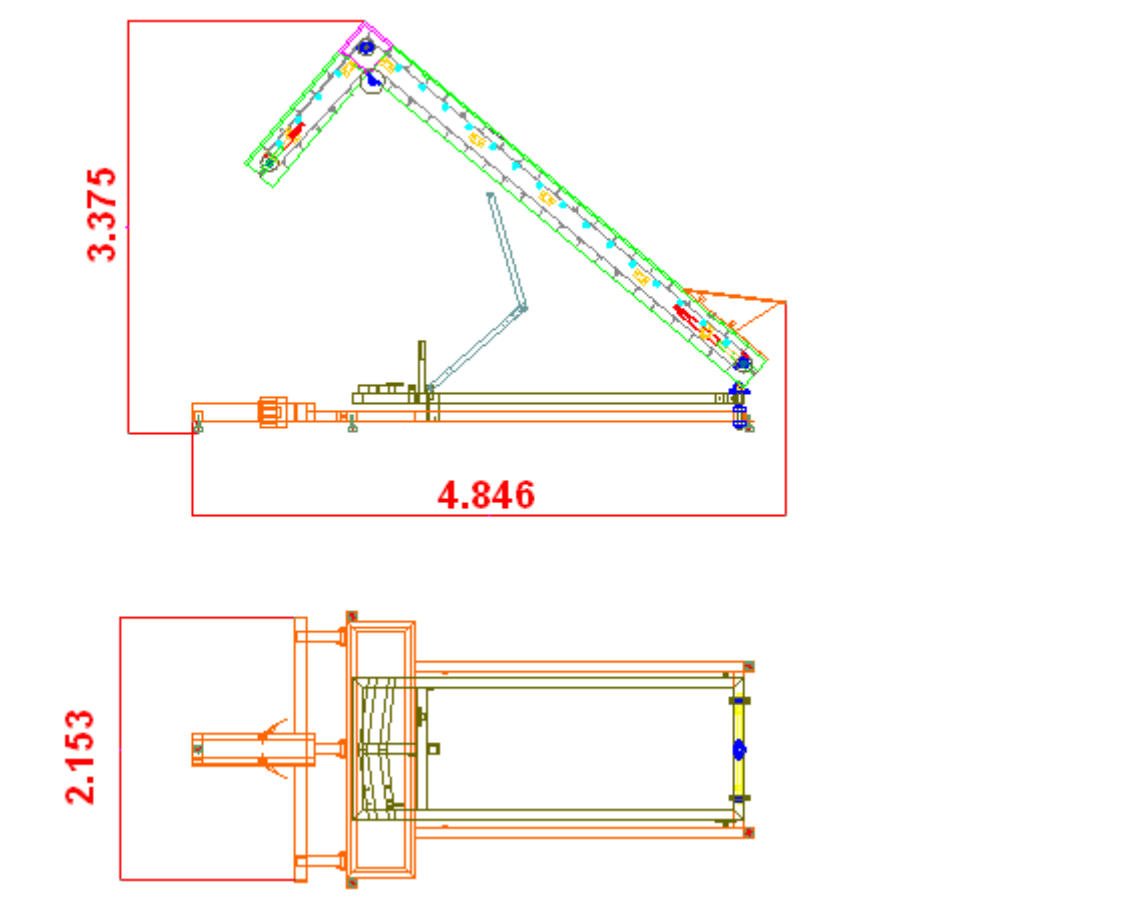
DOUBLE BOX FILLER LOS 640	Length: 4.846 mm Width: 2.153 mm Height: 3.375 mm
	

- Elevating conveyor with PVC belt.
- Specially designed to process up to 15 t/h.
- Power: 2,25 Kw.
- Robust, built entirely in stainless steel.
- This machine is completely automatic (all detectors included), although it can also be operated manually.
- Electric board included.
- CE Marking.
- The design is compact and efficient.
- Product and box detectors.
- The filler can work with one box only.
- Protection exit covers to care for the product during the filling action.
- Gliding turning movement from box to box that does not harm the product.
- The mechanisms are covered with a metal sheet that collects dirt and dust.

At **MARTIN MAQ** we know that you take great care of your product.

We know that this requires much effort and dedication. This is why we always place all our efforts in designing and manufacturing machines that will help you process your product efficiently, giving it the best possible finish.

We build all our machines to the highest of quality standards, making maintenance very easy and extending the machine's working life.

We have, at your disposal, an after-sales technical team that will assist you with any doubts that you may have during use and will inform you about how to care for your machine and keep maintenance as low as possible.

AFTER-SALES SERVICE

**ALWAYS REQUEST
ORIGINAL
MARTIN MAQ
SPARE PARTS**



I+D+I



FABRICACIÓN

**SERVICIO
POST VENTA**



REPUESTOS



MARTIN MAQ
Autovía A-601, Exit 91
40291 TABANERA LA LUENGA
Segovia (SPAIN)

T: +34-921-122 122
F: +34-921-57 70 88
e-mail: martinmaq@martinmaq.com
www.martinmaq.com

MARTIN MAQ Distributor:

