

ELIMINATION SYSTEM FOR SMALL WASTE VTH 915



M

Machinery manufactured in stainless steel following the best quality standards, providing the best finish and resistance.

M

More than 80 types of machines for processing all types of vegetables such as potatoes, carrots and fruit, unique design. Do not settle for mere copies.

A

Aadjustable in length, width and height with numerous sizes and designs to always provide the right solution to your needs.

Q

Quality, design and efficiency in all our machines to extend their working life and make your work as easy as possible.

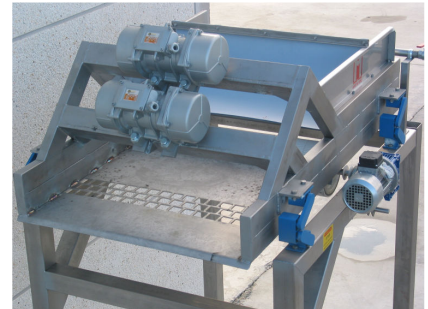

The **Martin Maq Elimination System for Small Waste VTH 915** takes care of disposing of all small pieces of product, leaves, weeds, etc ... before they reach the washer, polisher or grader.

With a strong structure and very easy to use, this small waste disposal system can process up to 10 t/h and eliminate practically all small waste, even the smallest (40 mm).

It is very small in size and can be placed without any problems within any existing line.

It is adjustable in height and inclination to be able to adapt to the different needs and type of product in a very easy way.



IMPORTANT PARTS OF THE MACHINE

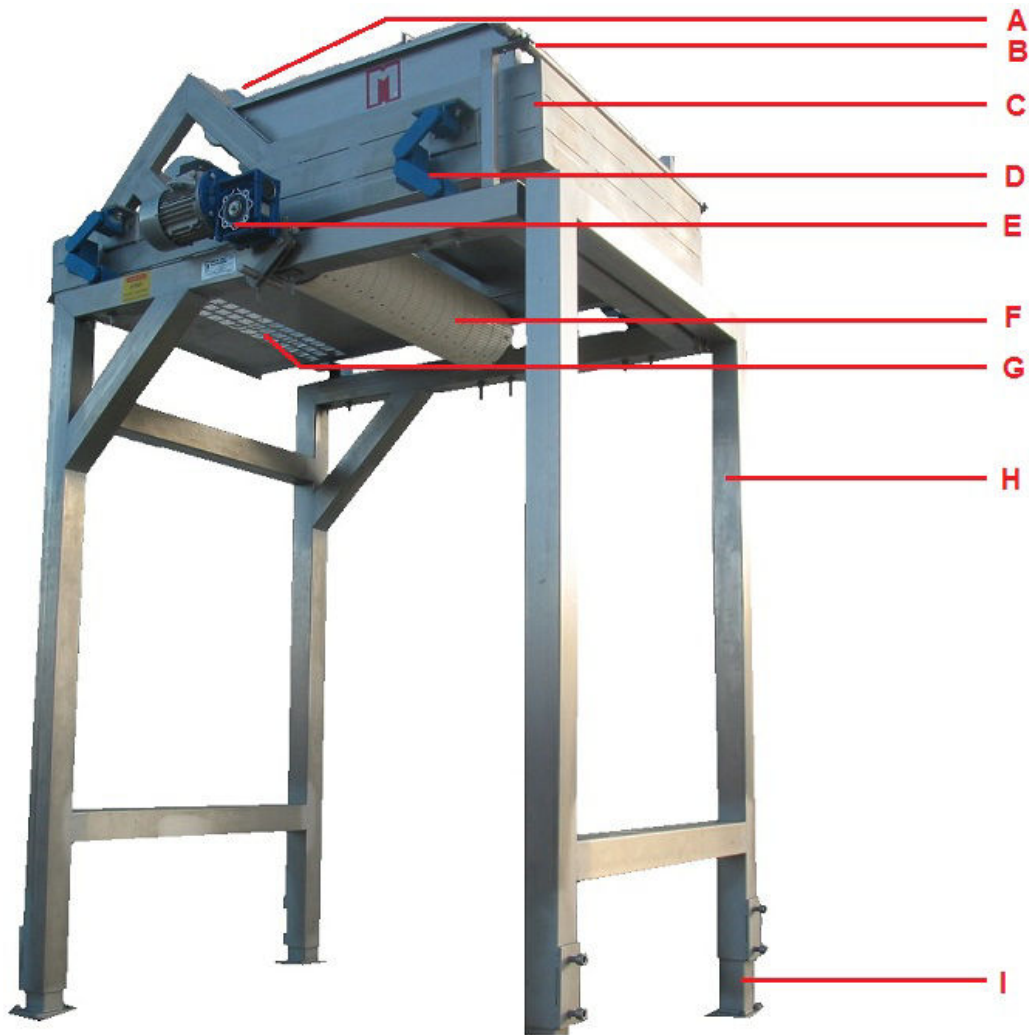

- A:** Vibrating motors to give movement to the tray.
- B:** Water sprays to operate the machine properly.
- C:** Resistant tray made of stainless steel.
- D:** Cushions / pads to absorb vibration from the tray.
- E:** Motor from the main roller.
- F:** Leave elimination roller.
- G:** Perforations on the tray to dispose of small pieces.
- I:** Strung and resistant structure in stainless steel.
- J:** Adjustable legs.

TECHNICAL SPECIFICATIONS

| | |
|---|--|
| ELIMINATION SYSTEM FOR SMALL WASTE VTH 915 | L: 1.598 mm w: 1.225 mm H: 1.723 mm + legs |
|---|--|

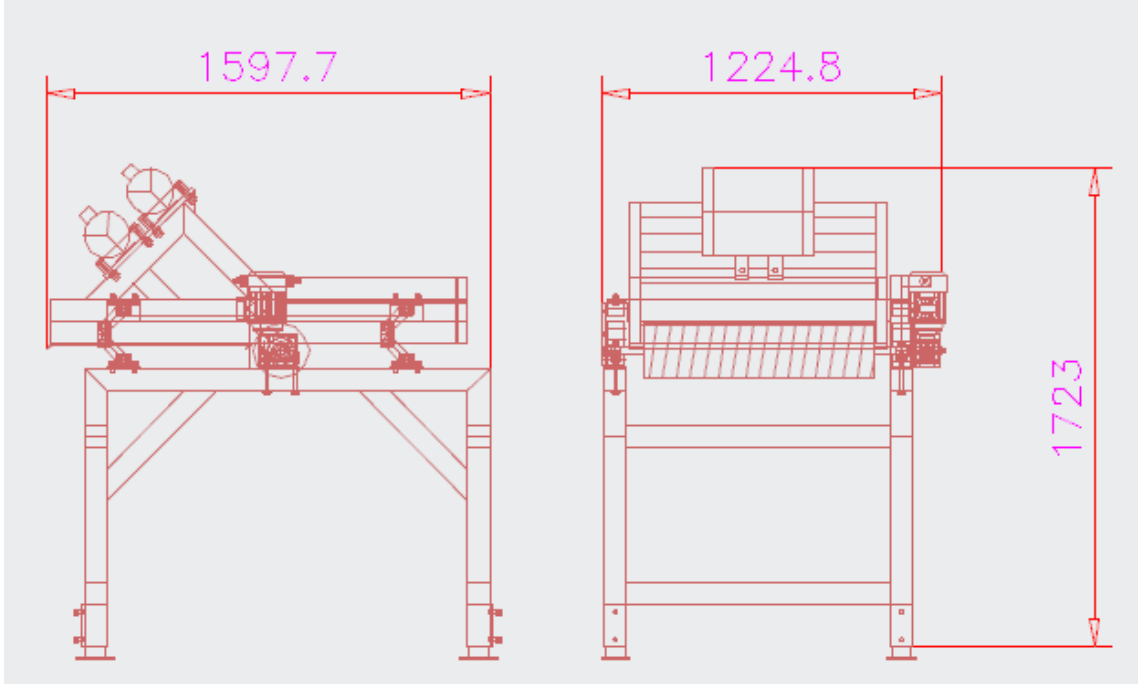

- It can process up to 10 T/h (carrots, turnips, etc.)
- Very efficient machine to dispose of small waste (40 mm approx.)
- Power: 1,1 KW.
- Anti-vibration pads to avoid vibration on the supports and other machines.
- Water consumption lower than 3 m³/hour.
- Adjustable in height and inclination.
- CE Marking.
- Efficient and compact design.

At **MARTIN MAQ** we know that you take great care of your product.

We know that this requires much effort and dedication. This is why we always place all our efforts in designing and manufacturing machines that will help you process your product efficiently, giving it the best possible finish.

We build all our machines to the highest of quality standards, making maintenance very easy and extending the machine's working life.

We have, at your disposal, an after-sales technical team that will assist you with any doubts that you may have during use and will inform you about how to care for your machine and keep maintenance as low as possible.

AFTER-SALES SERVICE

**ALWAYS REQUEST
ORIGINAL
MARTIN MAQ
SPARE PARTS**



I+D+I



FABRICACIÓN

**SERVICIO
POST VENTA**



REPUESTOS



MARTIN MAQ
Autovía A-601, Exit 91
40291 TABANERA LA LUENGA
Segovia (SPAIN)

T: +34-921-122 122
F: +34-921-57 70 88
e-mail: martinmaq@martinmaq.com
www.martinmaq.com

MARTIN MAQ Distributor:

