

LEAF ELIMINATION SYSTEM MEH 1415



M

Machinery manufactured in stainless steel following the best quality standards, providing the best finish and resistance.

M

More than 80 types of machines for processing all types of vegetables such as potatoes, carrots and fruit, unique design. Do not settle for mere copies.

A

Aadjustable in length, width and height with numerous sizes and designs to always provide the right solution to your needs.

Q

Quality, design and efficiency in all our machines to extend their working life and make your work as easy as possible.



The **MARTIN MAQ Leaf Elimination System MEH 1415** is the right machine to eliminate leaves that are still joined to the product (carrots ..) and that need to be separated before they reach the washer, polisher or grader.

Robust, built entirely in stainless steel, with an efficient and very simple and powerful working system, it is capable of a capacity of up to 10 t/h, eliminating practically all the leaves.

It has 15 axels that eliminate these leaves. It is adjustable in height and inclination to adapt to different needs or different products.

NOTE: It is essential that all stones from the product are removed before it enters this machine. This will save the machine from unnecessary breakages.





- A:** Non-splash cover.
- B:** Pipe with pressure exits.
- C:** Motor.
- D:** 15 axels to cut the leaves.
- E:** Inspection and maintenance lock-gates.
- F:** Electric board included.
- G:** Entry and exit band to protect the product from damage.
- H:** Adjustable legs (height and inclination)

TECHNICAL SPECIFICATIONS

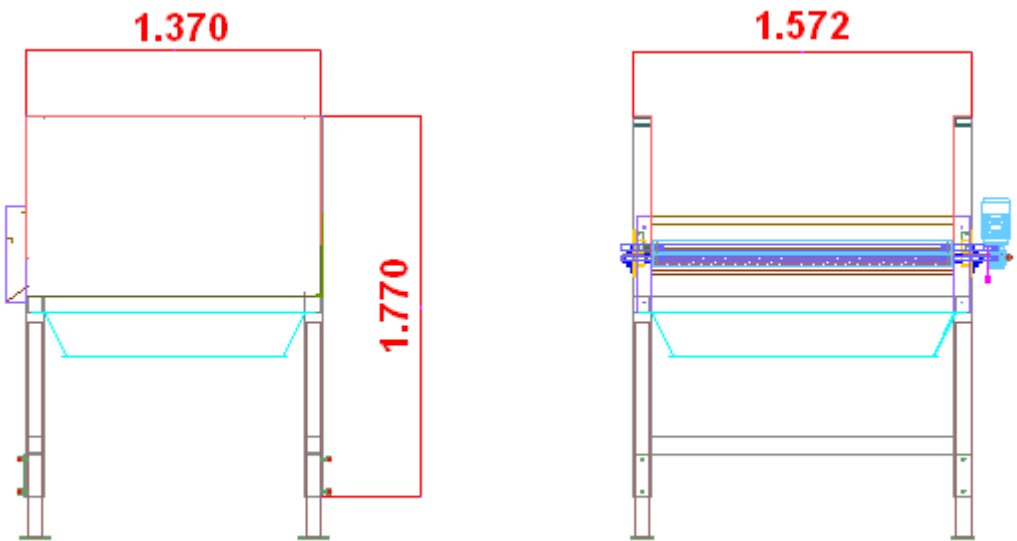
LEAF ELIMINATION SYSTEM MEH 1415	Length: 1.370 mm Width: 1.572 mm Height: 1.770 mm
	

- 15 rollers specially designed to eliminate leaves. Due to the way they are distributed, they make this machine very efficient.
- Capacity: Up to 10 t/h.
- Power: 3.85 KW with direct transmission, which provides strength when pulling the leaves, without damaging the product, due to the correct distribution of the axels.
- Robust, built entirely in stainless steel.
- Adjustable height and inclination.
- Adjustable water consumption.
- CE Marking.
- Efficient and compact design.
- Entry and exit product protection bands.

At **MARTIN MAQ** we know that you take great care of your product.

We know that this requires much effort and dedication. This is why we always place all our efforts in designing and manufacturing machines that will help you process your product efficiently, giving it the best possible finish.

We build all our machines to the highest of quality standards, making maintenance very easy and extending the machine's working life.

We have, at your disposal, an after-sales technical team that will assist you with any doubts that you may have during use and will inform you about how to care for your machine and keep maintenance as low as possible.

AFTER-SALES SERVICE

**ALWAYS REQUEST
ORIGINAL
MARTIN MAQ
SPARE PARTS**



I+D+I



FABRICACIÓN

**SERVICIO
POST VENTA**



REPUESTOS



MARTIN MAQ
Autovía A-601, Exit 91
40291 TABANERA LA LUENGA
Segovia (SPAIN)

T: +34-921-122 122
F: +34-921-57 70 88
e-mail: martinmaq@martinmaq.com
www.martinmaq.com

MARTIN MAQ Distributor:

