



**MARTIN MAQ<sup>®</sup>**

MAQUINARIA HORTICOLA  
VEGETABLE HANDLING SYSTEMS

## ROLLER INSPECTION TABLE MR 1240



# M

**M**achinery manufactured in stainless steel following the best quality standards, providing the best finish and resistance.

# M

**M**ore than 80 types of machines for processing all types of vegetables such as potatoes, carrots and fruit, unique design. Do not settle for mere copies.

# A

**A**adjustable in length, width and height with numerous sizes and designs to always provide the right solution to your needs.

# Q

**Q**uality, design and efficiency in all our machines to extend their working life and make your work as easy as possible.



This **MARTIN MAQ Roller Inspection Table MR1240** is the right machine to select potatoes and similar products in shape, because of the turning action of its rollers.

Indicated for productions of up to 15 t/h, it is very easy to use, with a variable speed adjuster and a central waste track that makes working on both sides of the table possible.

The whole machine is made of stainless steel. The rollers being in this material are long lasting and very easy to clean and maintain.

The machine has product protection covers at both ends (entry and exit), inspection and greasing lock-gates, adjustable legs



## IMPORTANT PARTS OF THE MACHINE

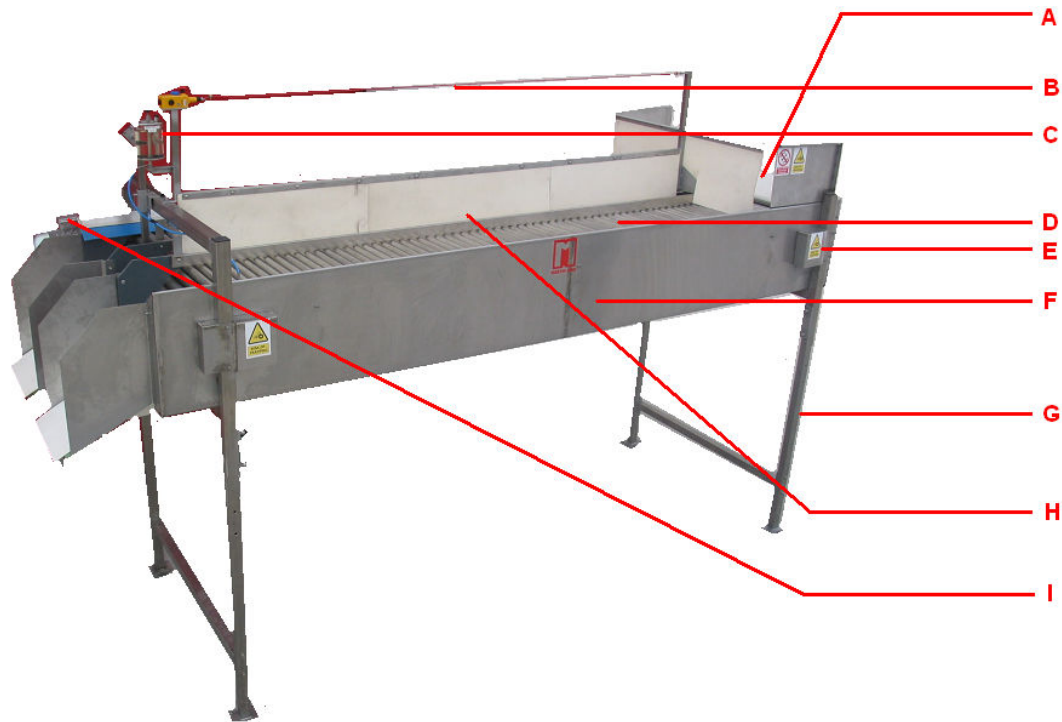

- A:** Product protection covers (entry and exit).
- B:** Emergency stop (either press button or pull string – optional)
- C:** Transmission chain self oiling system.
- D:** Stainless steel turning rollers to inspect product (two types depending on product)
- E:** Inspection and maintenance lock-gates for the transmission chain.
- F:** Robust built entirely in stainless steel.
- G:** Adjustable legs (height and inclination)
- H:** Central waste track.
- I:** Variable speed motor (mechanical) to control the amount of product to be inspected.

## MODEL

Two models with equal dimensions, only changing the diameter of the rollers which will depend on the product to be selected.

- **MR 1220 i 70:** Rollers with a diameter of 70 mm for potatoes, onions ...
- **MR 1220 i 44:** Rollers with a diameter of 44 mm for carrots, turnips ...

## TECHNICAL SPECIFICATIONS

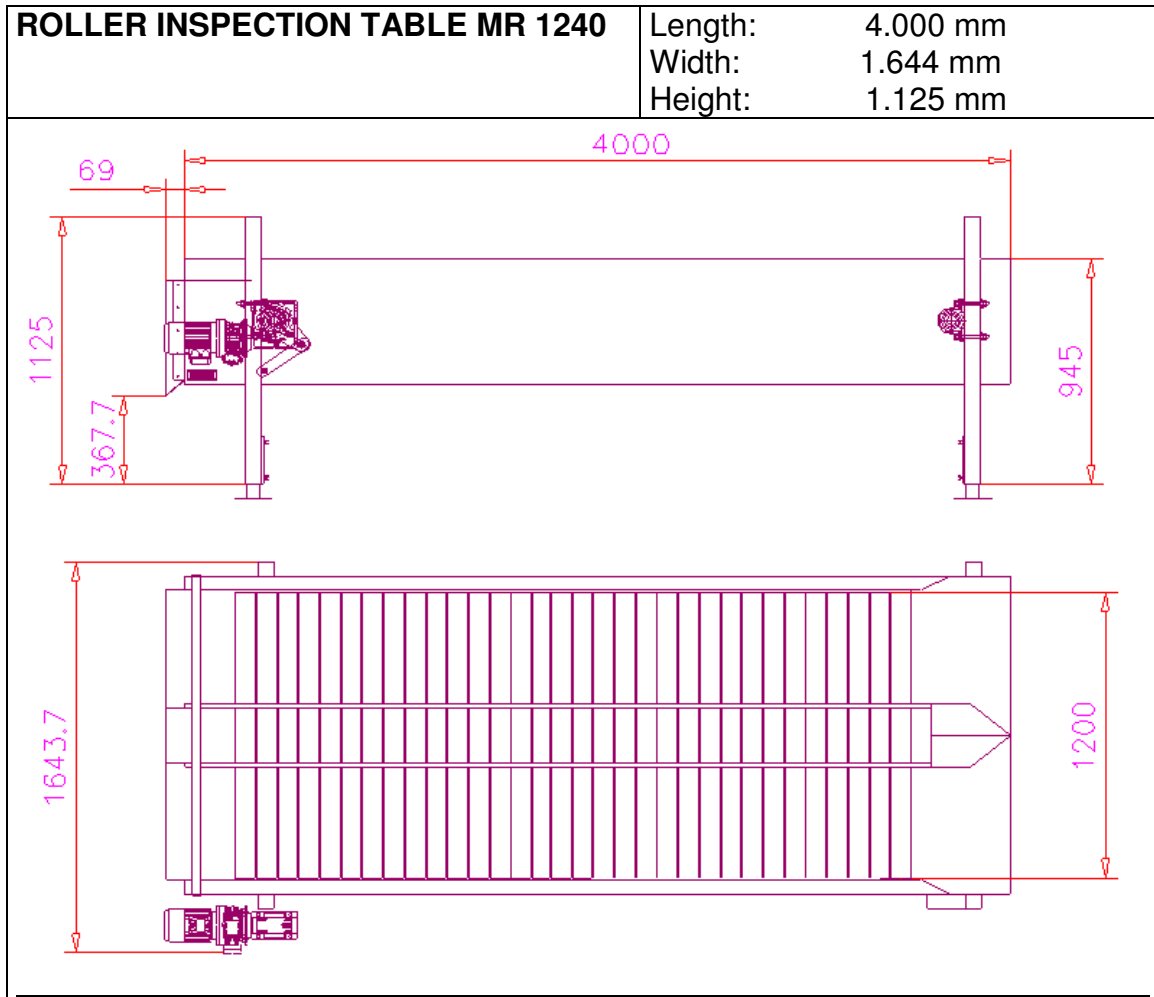

- Rollers 73 mm diameter in stainless steel, depending on the product.
- Processing capacity: 15 T/h.
- Power: 0.37 Kw with a very low electricity consumption.
- Motor with variable speed (mechanical) very easy to use.
- Robust, built entirely in stainless steel.
- Adjustable legs.
- CE Marking.
- Efficient and compact design.
- Product protection covers at entry and exit of the machine.
- Central waste track.

At **MARTIN MAQ** we know that you take great care of your product.

We know that this requires much effort and dedication. This is why we always place all our efforts in designing and manufacturing machines that will help you process your product efficiently, giving it the best possible finish.

We build all our machines to the highest of quality standards, making maintenance very easy and extending the machine's working life.

We have, at your disposal, an after-sales technical team that will assist you with any doubts that you may have during use and will inform you about how to care for your machine and keep maintenance as low as possible.

## AFTER-SALES SERVICE

\*\*\*\*

**ALWAYS REQUEST  
ORIGINAL  
MARTIN MAQ  
SPARE PARTS**



**I+D+I**



**FABRICACIÓN**

**SERVICIO  
POST VENTA**



**REPUESTOS**



**MARTIN MAQ**

Autovía A-601, Exit 91  
40291 TABANERA LA LUENGA  
Segovia (SPAIN)

T: +34-921-122 122  
F: +34-921-57 70 88  
e-mail: [martinmaq@martinmaq.com](mailto:martinmaq@martinmaq.com)  
[www.martinmaq.com](http://www.martinmaq.com)

MARTIN MAQ Distributor:

