

**ACCUMULATION HOPPER TA 222**



# M

**M**achinery manufactured in stainless steel following the best quality standards, providing the best finish and resistance.

# M

**M**ore than 80 types of machines for processing all types of vegetables such as potatoes, carrots and fruit, unique design. Do not settle for mere copies.

# A

**A**adjustable in length, width and height with numerous sizes and designs to always provide the right solution to your needs.

# Q

**Q**uality, design and efficiency in all our machines to extend their working life and make your work as easy as possible.



The **Martin Maq Accumulation Hopper TA222** is a machine designed to separate and accumulate the product in two different parts, being able to feed and be fed by to different conveyors.

Perfect to accumulate two sizes at the same time and in the same hopper. Product: carrots, turnips, etc

This machine can distribute (with all its width) a product efficiently and feed the machines that follow in a continuous way.

For lines with a capacity of up to 15 t/h. Built in stainless steel and covered with a soft material that acts as a buffer and avoids damage to the product.

Very low maintenance and easy to clean.



## IMPORTANT PARTS OF THE MACHINE

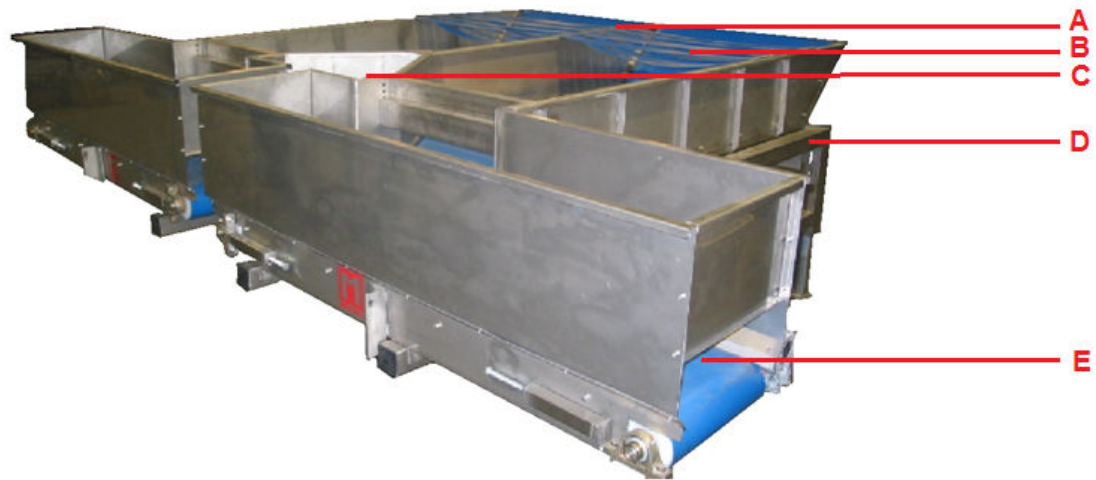

- A:** Vibration tray covered in a padded material that protects the product, product which is divided in two separated sides.
- B:** Cushioning system.
- C:** Exit bifurcation with two exits (one for each side of the hopper)
- D:** Strong, built in stainless steel.
- E:** Exit conveyors (optional, being able to go in the same direction or perpendicular).

## TECHNICAL SPECIFICATIONS

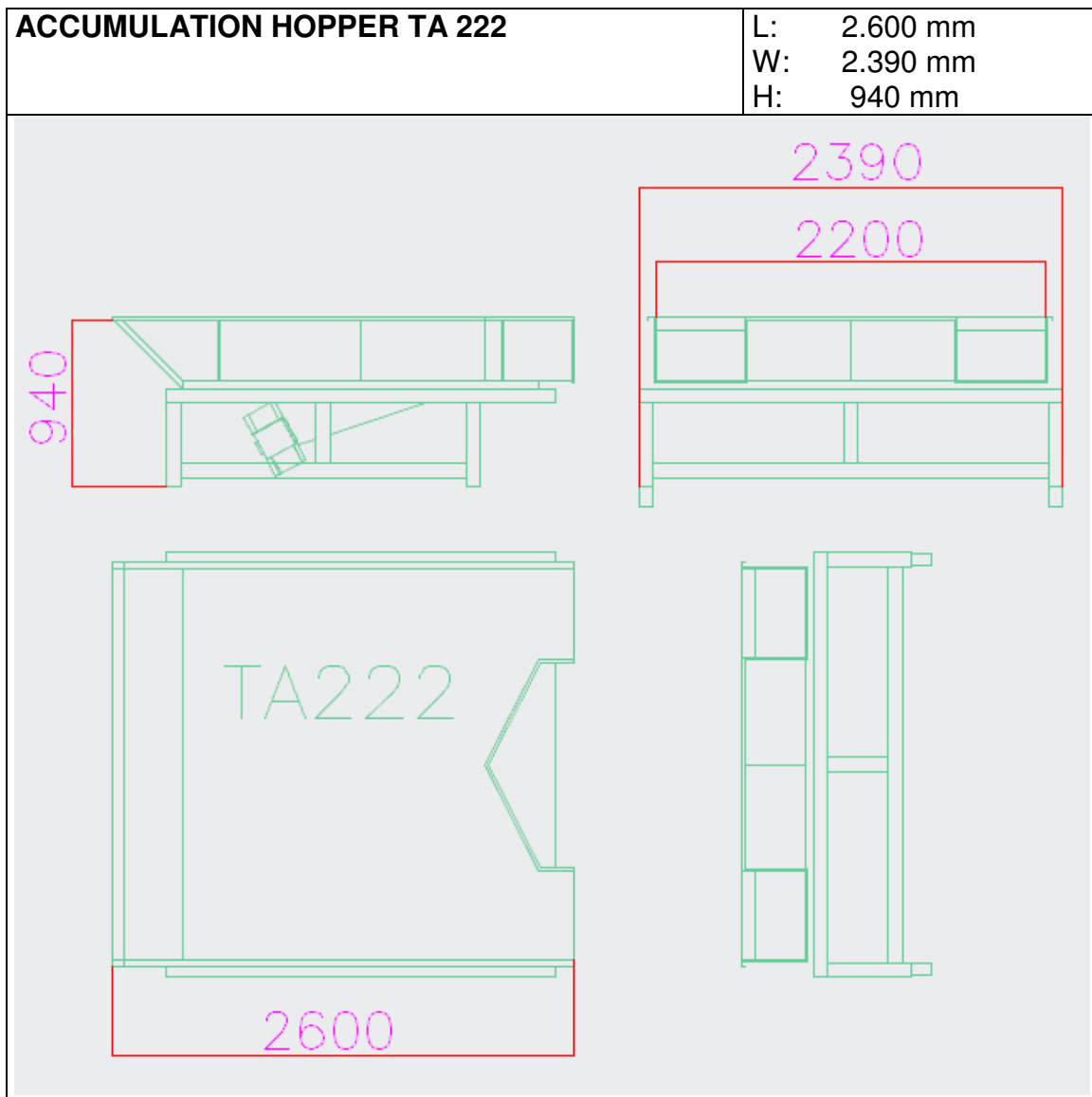

- Maximum Capacity 15 T/h.
- Power 0.75 KW.
- Easy and low maintenance.
- Exit protection covers (optional).
- Protection stripes for the product when filling the hopper.
- Cushioning system.
- Padded tray to avoid damage to the product.
- Vibration system to distribute the product correctly.
- Weight 800 Kg.
- Two separate sides, each one with an exit.
- CE Marking.

At **MARTIN MAQ** we know that you take great care of your product.

We know that this requires much effort and dedication. This is why we always place all our efforts in designing and manufacturing machines that will help you process your product efficiently, giving it the best possible finish.

We build all our machines to the highest of quality standards, making maintenance very easy and extending the machine's working life.

We have, at your disposal, an after-sales technical team that will assist you with any doubts that you may have during use and will inform you about how to care for your machine and keep maintenance as low as possible.

## AFTER-SALES SERVICE

\*\*\*\*

**ALWAYS REQUEST  
ORIGINAL  
MARTIN MAQ  
SPARE PARTS**



**I+D+I**



**FABRICACIÓN**

**SERVICIO  
POST VENTA**



**REPUESTOS**



### **MARTIN MAQ**

Autovía A-601, Exit 91  
40291 TABANERA LA LUENGA  
Segovia (SPAIN)

T: +34-921-122 122  
F: +34-921-57 70 88  
e-mail: [martinmaq@martinmaq.com](mailto:martinmaq@martinmaq.com)  
[www.martinmaq.com](http://www.martinmaq.com)

MARTIN MAQ Distributor:

