

**VIBRATION HOPPER WITH ROLLER 1615RO**



# M

**M**achinery manufactured in stainless steel following the best quality standards, providing the best finish and resistance.

# M

**M**ore than 80 types of machines for processing all types of vegetables such as potatoes, carrots and fruit, unique design. Do not settle for mere copies.

# A

**A**adjustable in length, width and height with numerous sizes and designs to always provide the right solution to your needs.

# Q

**Q**uality, design and efficiency in all our machines to extend their working life and make your work as easy as possible.



The **MARTIN MAQ Vibration Hopper** has the purpose of eliminating leaves. Products are: carrots, parsnips, etc ...

Furthermore, apart from eliminating loose leaves, it distributes the product efficiently to feed correctly the machines that follow in a continuous way.

Built in stainless steel and covered with a unique cushioning material that absorbs the vibration without damaging the product.

Incorporated are water sprays (optional and depending on customer's needs) that improve the cleaning and elimination of leaves.

Very easy to clean and low maintenance.



## IMPORTANT PARTS OF THE MACHINE

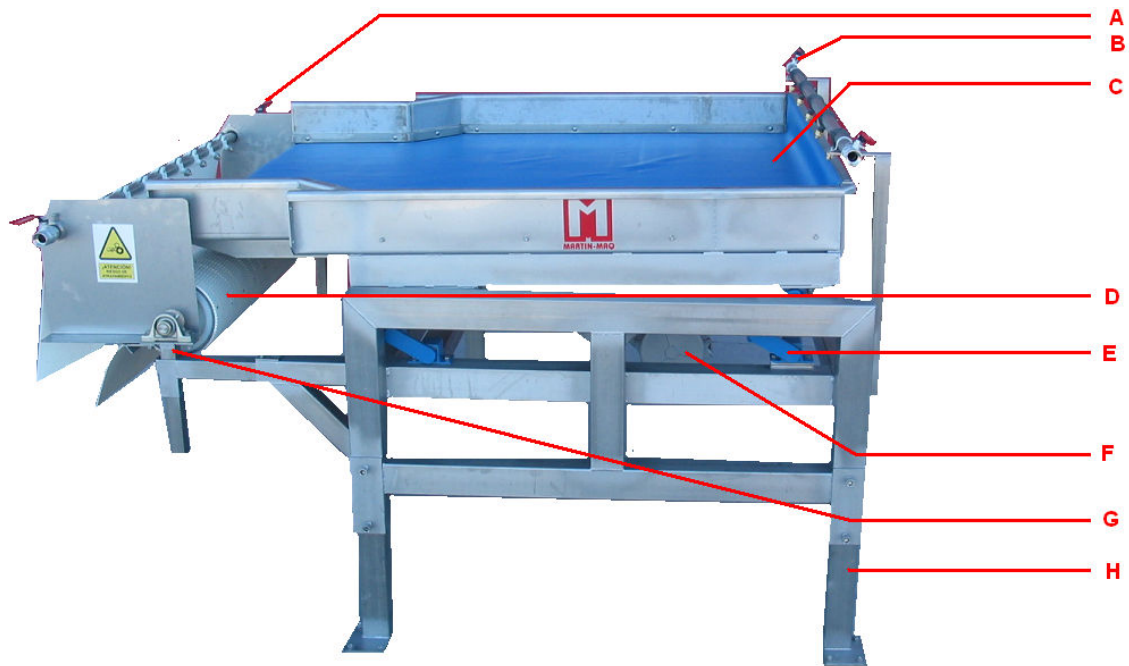

**A:** Water sprays for cleaning.

**B:** Water sprays at entry of the product in the machine that helps to loosen the leaves.

**C:** Padded vibration tray.

**D:** Leaves elimination roller. Perfect to take away leaves that are already loose.

**E:** Cushioning system.

**F:** Motor-vibrators.

**G:** Adjustable height. Roller for eliminating leaves can be moved and adjusted.

**H:** Adjustable height.

## TECHNICAL SPECIFICATIONS

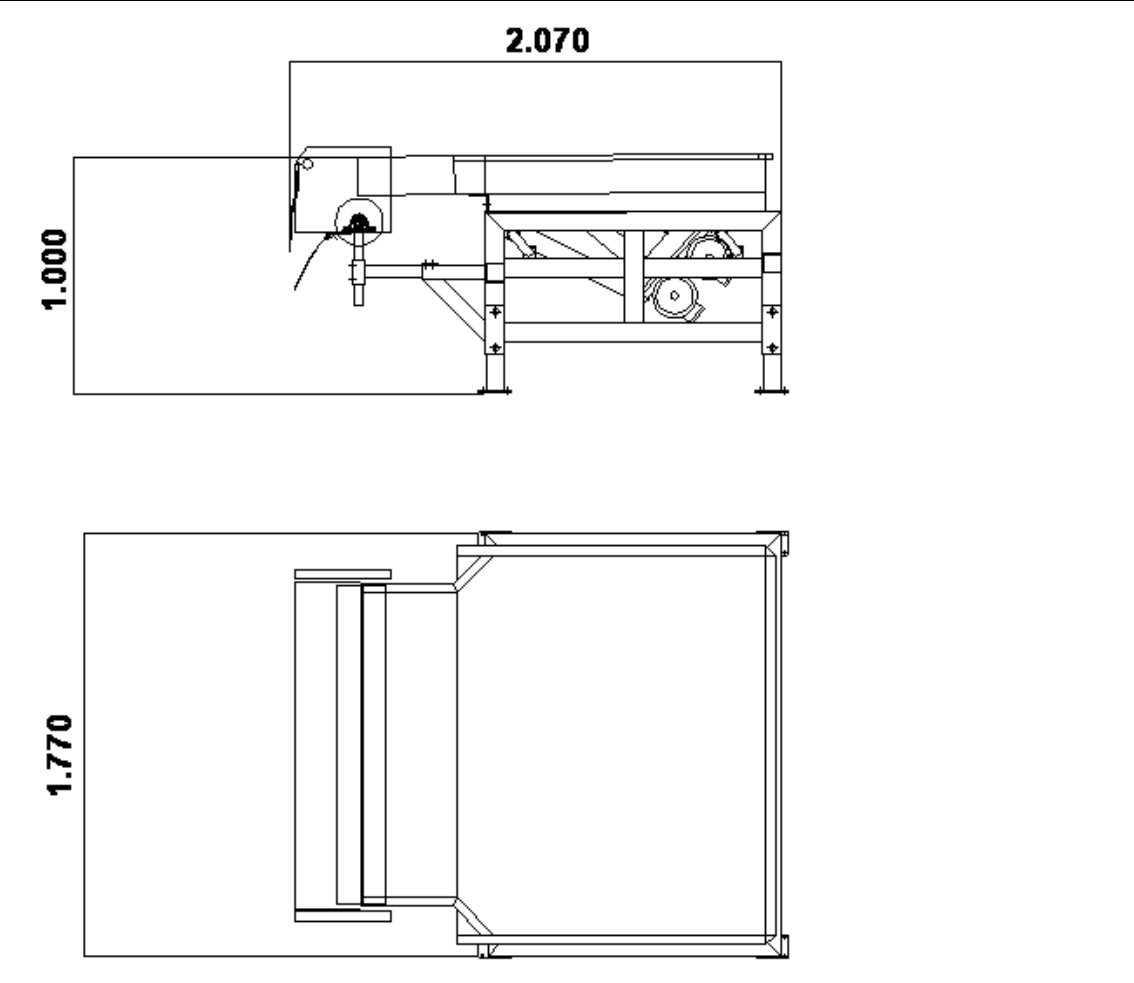
<b>VIBRATION HOPPER WITH ROLLER TD 1615RO</b>	Length: 2.070 mm Width: 1.770 mm Heights: 1.000 mm
	

- Low water consumption. The amount will depend on production and water spray's system.
- Capacity: 15 T / h.
- Power: 1.1 KW.
- Robust, made in stainless steel.
- CE Marking.
- Easy and low maintenance and cleaning.
- Exit bands to protect the product.
- Highly efficient eliminating roller.
- Water rinsing spray's at machine's exit.
- Adjustable legs.
- Unique cushioning system.
- Padded tray to avoid damage to the product.
- Unique vibration system to distribute the product evenly.
- Weight: 430 Kg.

At **MARTIN MAQ** we know that you take great care of your product.

We know that this requires much effort and dedication. This is why we always place all our efforts in designing and manufacturing machines that will help you process your product efficiently, giving it the best possible finish.

We build all our machines to the highest of quality standards, making maintenance very easy and extending the machine's working life.

We have, at your disposal, an after-sales technical team that will assist you with any doubts that you may have during use and will inform you about how to care for your machine and keep maintenance as low as possible.

## AFTER-SALES SERVICE

\*\*\*\*

**ALWAYS REQUEST  
ORIGINAL  
MARTIN MAQ  
SPARE PARTS**



**I+D+I**



**FABRICACIÓN**

**SERVICIO  
POST VENTA**



**REPUESTOS**



**MARTIN MAQ**

Autovía A-601, Exit 91  
40291 TABANERA LA LUENGA  
Segovia (SPAIN)

T: +34-921-122 122  
F: +34-921-57 70 88  
e-mail: [martinmaq@martinmaq.com](mailto:martinmaq@martinmaq.com)  
[www.martinmaq.com](http://www.martinmaq.com)

MARTIN MAQ Distributor:

