



MARTIN MAQ[®]

MAQUINARIA HORTICOLA
VEGETABLE HANDLING SYSTEMS

RECEIVING HOPPER TRI 625



M

Machinery manufactured in stainless steel following the best quality standards, providing the best finish and resistance.

M

More than 80 types of machines for processing all types of vegetables such as potatoes, carrots and fruit, unique design. Do not settle for mere copies.

A

Aadjustable in length, width and height with numerous sizes and designs to always provide the right solution to your needs.

Q

Quality, design and efficiency in all our machines to extend their working life and make your work as easy as possible.



The **MARTIN MAQ Receiving Hopper TRI 625** is the adequate machine to receive the product from the tipper, or to act as an accumulator at some point within the line. Products: carrots, potatoes,

Maximum storing capacity: 1,5 tons .
Design to feed a processing line between 5 y 10 T / h.

Robust machine, in stainless steel with a very strong and resistant rubber band that can cope with the wear and tear caused by the earth and waste that it carries.

It has a motor with a mechanical speed adjuster, that controls the amount of product being processed by the line.

Very low maintenance



IMPORTANT PARTS OF THE MACHINE

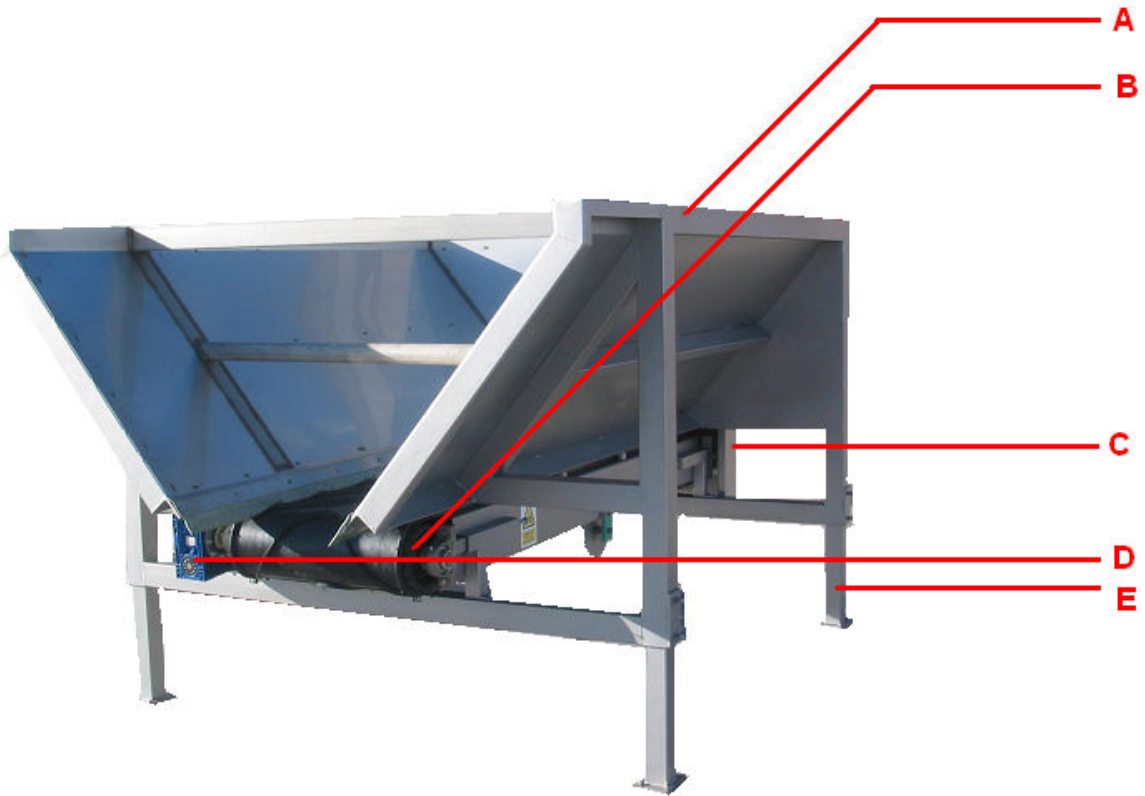

A: Robust, built in stainless steel and reinforced.

B: Rubber band.

C: Conveyor's lock-gate for maintenance.

D: Speed adjuster for the motor.

E: Adjustable legs.

TECHNICAL SPECIFICATIONS

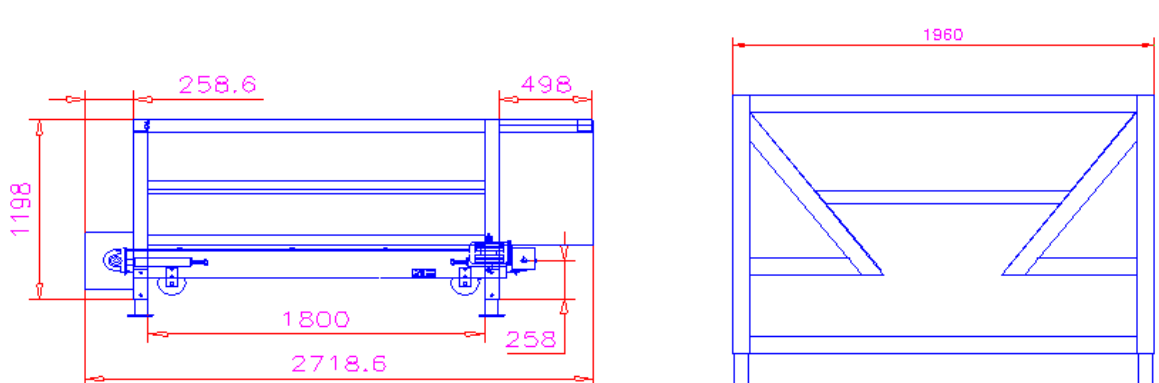
RECEIVING HOPPER TRI 625	Length: 2.719 mm Width: 1.960mm Height: 1.200+LEGS
	

- Built in stainless steel.
- Rubber band 600 mm wide and 2.500 mm long. Highly resistant.
- Capacity:1.5 T.
- Adequate for lines of a capacity: 5 and 10 T / h.
- Specially designed to follow the tippers.
- Power, depending on the lines capacity: 0,37 KW.
- Inspection lock-gates.
- Adjustable legs.
- Motor with speed adjuster.
- Easy maintenance and cleaning.

At **MARTIN MAQ** we know that you take great care of your product.

We know that this requires much effort and dedication. This is why we always place all our efforts in designing and manufacturing machines that will help you process your product efficiently, giving it the best possible finish.

We build all our machines to the highest of quality standards, making maintenance very easy and extending the machine's working life.

We have, at your disposal, an after-sales technical team that will assist you with any doubts that you may have during use and will inform you about how to care for your machine and keep maintenance as low as possible.

AFTER-SALES SERVICE

**ALWAYS REQUEST
ORIGINAL
MARTIN MAQ
SPARE PARTS**



I+D+i



FABRICACIÓN

**SERVICIO
POST VENTA**



REPUESTOS



MARTIN MAQ

Autovía A-601, Exit 91
40291 TABANERA LA LUENGA
Segovia (SPAIN)

T: +34-921-122 122
F: +34-921-57 70 88
e-mail: martinmaq@martinmaq.com
www.martinmaq.com

MARTIN MAQ Distributor:

