

**RECEIVING HOPPER TRI 650B**

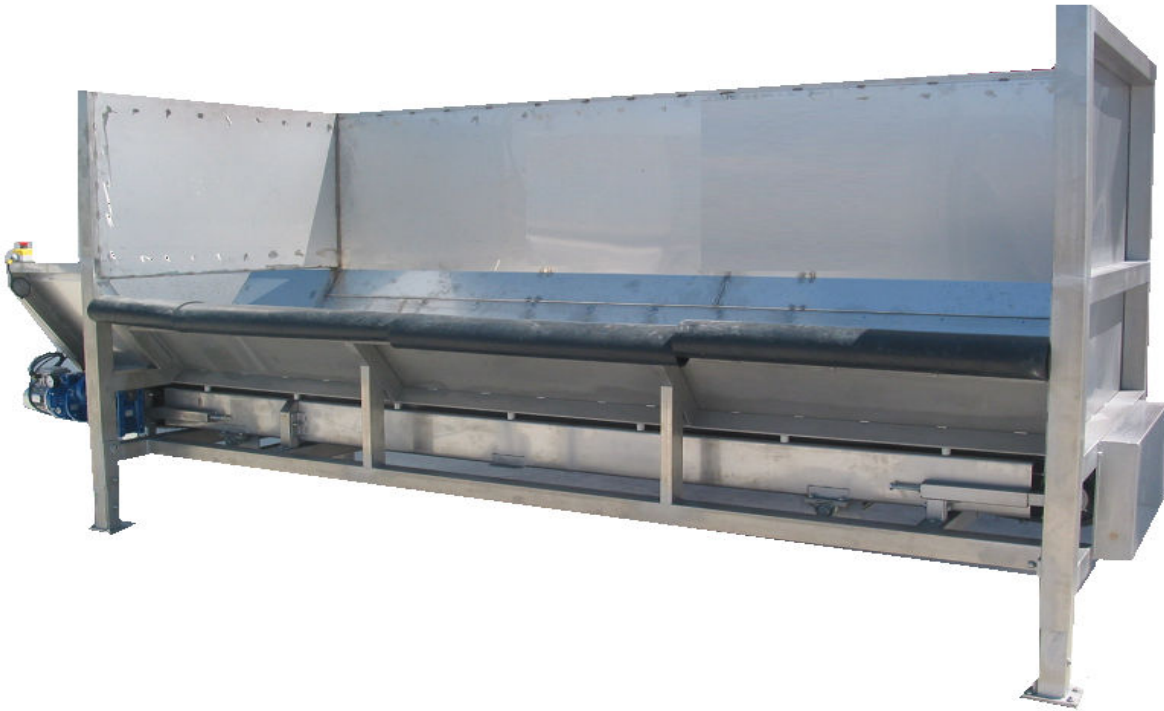

# M

**M**achinery manufactured in stainless steel following the best quality standards, providing the best finish and resistance.

# M

**M**ore than 80 types of machines for processing all types of vegetables such as potatoes, carrots and fruit, unique design. Do not settle for mere copies.

# A

**A**adjustable in length, width and height with numerous sizes and designs to always provide the right solution to your needs.

# Q

**Q**uality, design and efficiency in all our machines to extend their working life and make your work as easy as possible.



The **MARTIN MAQ Receiving Hopper TRI650B** is the perfect solution to receive the product directly from trucks or tippers.

It has a capacity of 3,5 tons of product ( carrots, potatoes, turnips...)

It is indicated for processing lines with a capacity of 15 tons per hour.

Its all made in stainless steel and the band is made of rubber. For these reasons this machine is strong and with a long life.

The motor has a speed drive controller to regulate the amount of product that leaves the hopper.

Also, it has protecting shock absorber bibs.



## IMPORTANT PARTS OF THE MACHINE

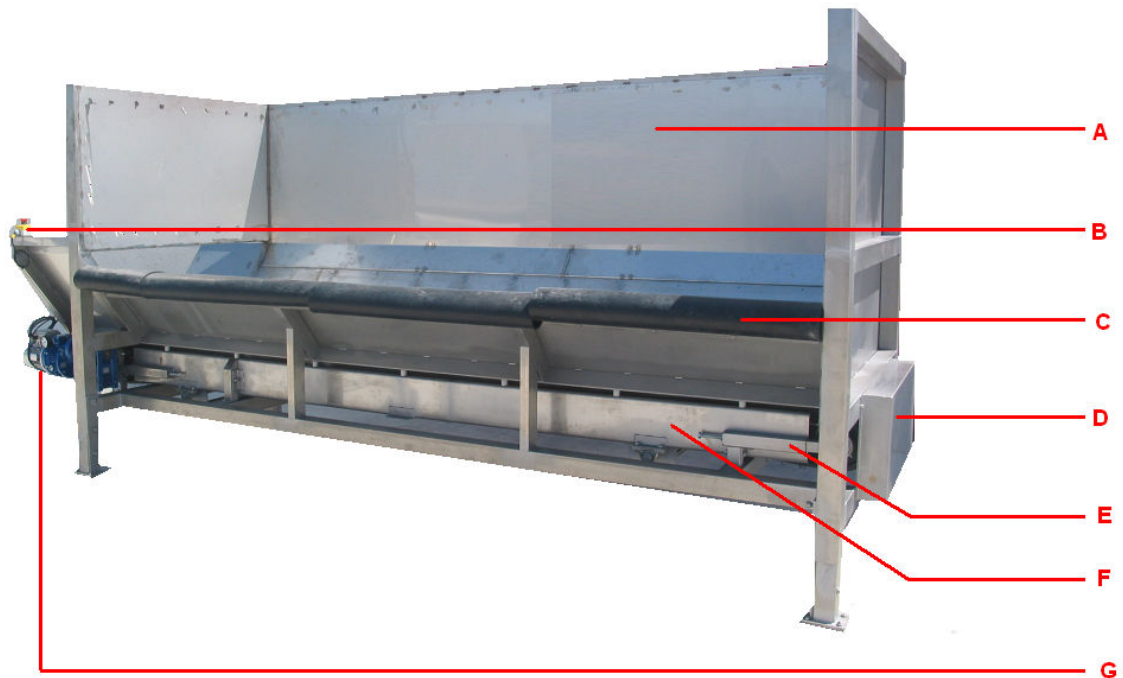

**A:** Optional sidewall (if you only feed it on one side).

**B:** Emergency stop.

**C:** Rubber protecting bibs.

**D:** Service trap.

**E:** Belt tensioners on both sides.

**F:** Rubber ribbed belt conveyor.

**G:** Motor with speed drive controller.

**OPCIÓN:** Adjustable legs.

## TECHNICAL SPECIFICATIONS

### RECEIVING HOPPER TRI 650B

L: 4.963 mm  
W: 1.500 mm  
H: 1000+LEGS

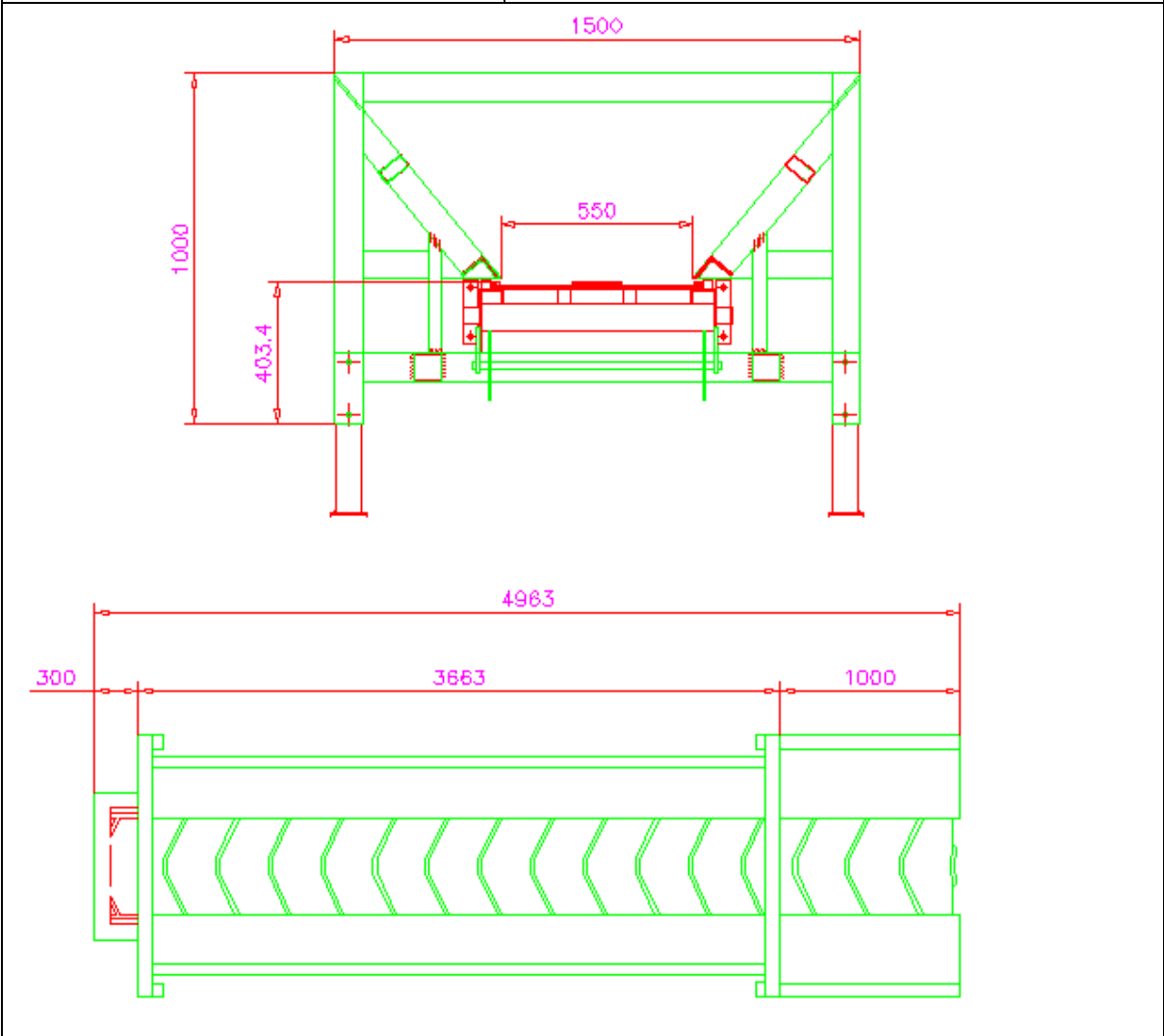

- Stainless steel.
- Rubber band 600 mm wide.
- Capacity = 3,5 tons.
- Appropriated for lines that process 15 tons per hour or more.
- Designed to be fed by trucks or tippers.
- Total power: 0,9 KW. 60 Hz.
- Inspection traps.
- Protecting rubber bibs.

At **MARTIN MAQ** we know that you take great care of your product.

We know that this requires much effort and dedication. This is why we always place all our efforts in designing and manufacturing machines that will help you process your product efficiently, giving it the best possible finish.

We build all our machines to the highest of quality standards, making maintenance very easy and extending the machine's working life.

We have, at your disposal, an after-sales technical team that will assist you with any doubts that you may have during use and will inform you about how to care for your machine and keep maintenance as low as possible.

## AFTER-SALES SERVICE

\*\*\*\*

**ALWAYS REQUEST  
ORIGINAL  
MARTIN MAQ  
SPARE PARTS**



**I+D+i**



**FABRICACIÓN**

**SERVICIO  
POST VENTA**



**REPUESTOS**



### **MARTIN MAQ**

Autovía A-601, Exit 91  
40291 TABANERA LA LUENGA  
Segovia (SPAIN)

T: +34-921-122 122

F: +34-921-57 70 88

e-mail: [martinmaq@martinmaq.com](mailto:martinmaq@martinmaq.com)

[www.martinmaq.com](http://www.martinmaq.com)

MARTIN MAQ Distributor:

