

**WASHER – PEELER – CUTTER LPC 20**



# M

**M**achinery manufactured in stainless steel following the best quality standards, providing the best finish and resistance.

# M

**M**ore than 80 types of machines for processing all types of vegetables such as potatoes, carrots and fruit, unique design. Do not settle for mere copies.

# A

**A**adjustable in length, width and height with numerous sizes and designs to always provide the right solution to your needs.

# Q

**Q**uality, design and efficiency in all our machines to extend their working life and make your work as easy as possible.

---

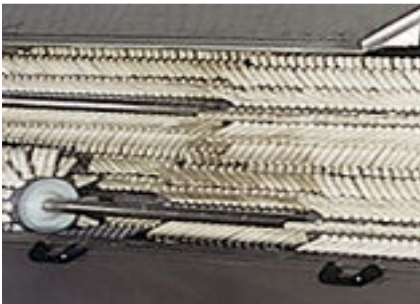

---

The **Martin Maq Washer – Peeler – Cutter LPC 20 LPC17** is a machine designed to wash the product (leeks and spring onions mainly), peel the outer leaves and cut the upper end of the leaves that can not be used.

Inside it has pressure water sprays, high precision blades and rotating “fingers” that peel dry leaves.

Adjustable in speed and cutting length and adequate for a capacity of 8.000 to 12.000 units per hour.



## IMPORTANT PARTS OF THE MACHINE



- A:** Exit conveyors.
- B:** Structure completely closed to avoid any danger when being used (blades).
- C:** Electric board with speed adjusters, product / unit counter (optional) etc.
- D:** Entry conveyor with placing device to improve the process (device optional).
- E:** Lower box for water collection.
- F:** Adjustable legs.
- G:** Two axels with “fingers” and parallel brushes to eliminate the outer layers of the product.
- H:** Leave cutting blades. Other sets of blades optional.
- I:** Pressure water sprays for washing the product.

**NOTE: This machine can be purchased with a water recycling deposit.**

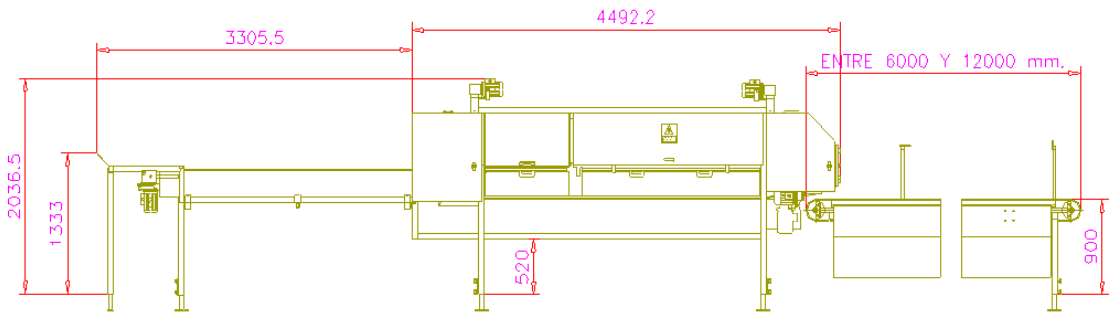

## TECHNICAL SPECIFICATIONS

<b>WASHER-CUTTER-PEELER LPC 20</b>	L: 6.000mm + exit conveyor W: 1.250 mm H: 1.975 mm
	

- Specially designed for **leeks and spring onions**.
- Entry conveyor with placing device to support product.
- Capacity: between 8.000 and 12.000 units.
- Water consumption: between 18 and 25 m<sup>3</sup> /hour.
- Protection side mesh following safety rules and regulations.
- Automatic and manual devices for the correct working of the machine.
- Power: 4.2 KW
- Weight 1.200 Kg (depending on options).
- CE Marking
- Mechanisms totally closed to avoid any danger.
- Electric board included.
- Exit conveyor of 4,5,6,7,8 or meters.
- Water recycling deposit optional, that includes pump.

At **MARTIN MAQ** we know that you take great care of your product.

We know that this requires much effort and dedication. This is why we always place all our efforts in designing and manufacturing machines that will help you process your product efficiently, giving it the best possible finish.

We build all our machines to the highest of quality standards, making maintenance very easy and extending the machine's working life.

We have, at your disposal, an after-sales technical team that will assist you with any doubts that you may have during use and will inform you about how to care for your machine and keep maintenance as low as possible.

## AFTER-SALES SERVICE

\*\*\*\*

**ALWAYS REQUEST  
ORIGINAL  
MARTIN MAQ  
SPARE PARTS**



**I+D+I**



**FABRICACIÓN**

**SERVICIO  
POST VENTA**



**REPUESTOS**



**MARTIN MAQ**  
Autovía A-601, Exit 91  
40291 TABANERA LA LUENGA  
Segovia (SPAIN)

T: +34-921-122 122  
F: +34-921-57 70 88  
e-mail: [martinmaq@martinmaq.com](mailto:martinmaq@martinmaq.com)  
[www.martinmaq.com](http://www.martinmaq.com)

MARTIN MAQ Distributor:

