



MARTIN MAQ®

MAQUINARIA HORTICOLA
VEGETABLE HANDLING SYSTEMS

LENGTH GRADER CALONG 8 TH



M

Machinery manufactured in stainless steel following the best quality standards, providing the best finish and resistance.

M

More than 80 types of machines for processing all types of vegetables such as potatoes, carrots and fruit, unique design. Do not settle for mere copies.

A

Aadjustable in length, width and height with numerous sizes and designs to always provide the right solution to your needs.

Q

Quality, design and efficiency in all our machines to extend their working life and make your work as easy as possible.



The **MARTIN MAQ Length Grader CALONG 8 th** can size carrots, parsnips, etc., as well as separating small pieces (waste) and position the product correctly before it enters the following machines should this be the case.

It works by vibration and it can achieve a correct grading for an output of up to 10 t/h.

This grader can work with the necessary conveyors, each one collecting a different size.



IMPORTANT PARTS OF THE MACHINE

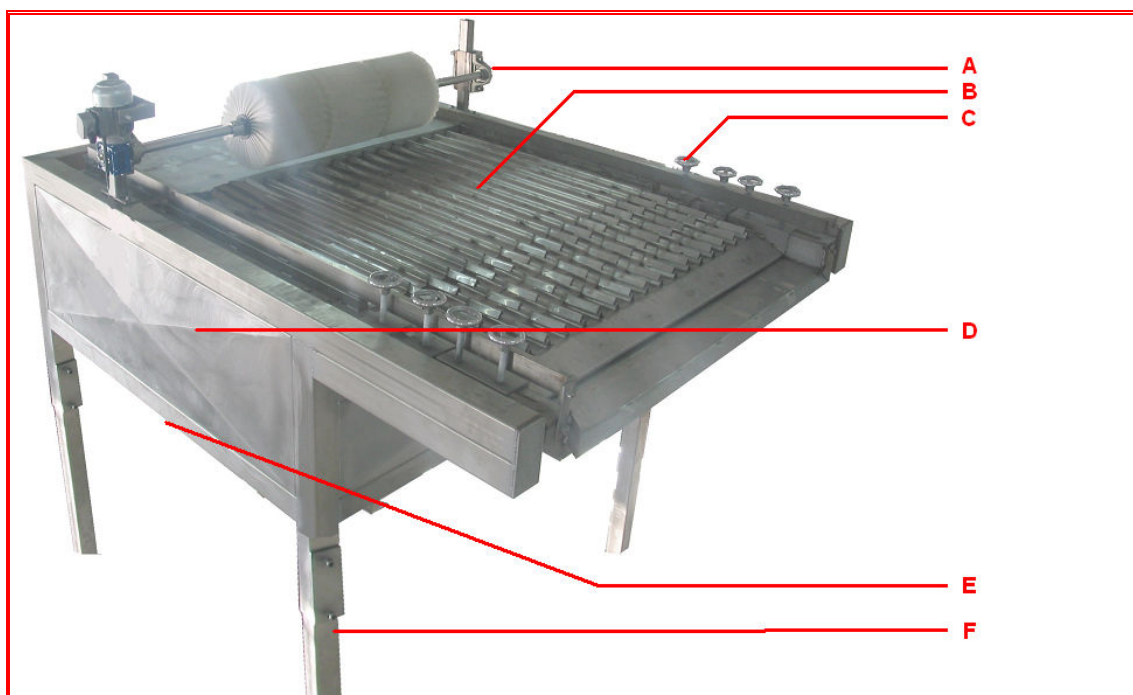

A: Product aligning brush, optional, depending on the machine positioned before this one.

B: Vibrating tray to position product.

C: Manual grading adjusters, to size lengths of 2, 3 or 4 grades (depending on need).

D: Mechanical speed adjusters for processing the product.

E: Vibrating system positioned under the machine (two motors).

F: Adjustable legs.

TECHNICAL SPECIFICATIONS

LENGTH GRADER CALONG 8 TH	Length:	2.248 mm
	Width:	1.710 mm
	Height:	1.135 mm

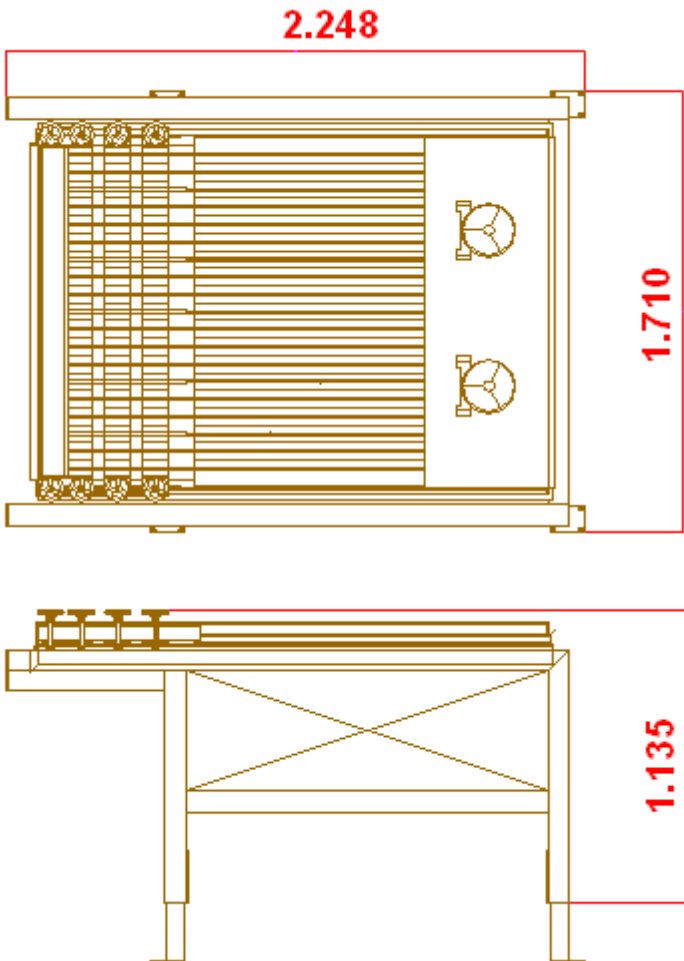

- Vibration system based on two-motor vibrators.
- Vibrating tray with 14 rows.
- Manual system to regulate the different grades.
- Grading options: 2 or 3 grades plus a final grade.
- Robust, built in stainless steel.
- Product protection bands at entry of machine.
- Processing speed adjuster (motor-vibration).
- Output: Up to 10 T/h
- Product: carrots, parsnips ...
- Weight: 475 Kg (depending on model and options).
- Rotating brush to help process the product (optional)
- Power: 1.4 KW (without the above mentioned brush which is optional).

At **MARTIN MAQ** we know that you take great care of your product.

We know that this requires much effort and dedication. This is why we always place all our efforts in designing and manufacturing machines that will help you process your product efficiently, giving it the best possible finish.

We build all our machines to the highest of quality standards, making maintenance very easy and extending the machine's working life.

We have, at your disposal, an after-sales technical team that will assist you with any doubts that you may have during use and will inform you about how to care for your machine and keep maintenance as low as possible.

AFTER-SALES SERVICE

**ALWAYS REQUEST
ORIGINAL
MARTIN MAQ
SPARE PARTS**



I+D+I



FABRICACIÓN

**SERVICIO
POST VENTA**



REPUESTOS



MARTIN MAQ
Autovía A-601, Exit 91
40291 TABANERA LA LUENGA
Segovia (SPAIN)

T: +34-921-122 122
F: +34-921-57 70 88
e-mail: martinmaq@martinmaq.com
www.martinmaq.com

MARTIN MAQ Distributor:

