

RECYCLING AND FILTERING TANK DERE 1014



M

Machinery manufactured in stainless steel following the best quality standards, providing the best finish and resistance.

M

More than 80 types of machines for processing all types of vegetables such as potatoes, carrots and fruit, unique design. Do not settle for mere copies.

A

Aadjustable in length, width and height with numerous sizes and designs to always provide the right solution to your needs.

Q

Quality, design and efficiency in all our machines to extend their working life and make your work as easy as possible.



The **MARTIN MAQ Recycling and Filtering Tank DERE 1014** is used to accumulate water from the washer, polisher, etc. to its later use.

Due to its design we can fix to this tank, 2, 3 or 4 deposits in line, to make the filtering completely effective with different size filters.

Filtering capacity between 15 to 150 m³ per hour, depending on the number of deposits, deposits which are accessible with a fork lift truck to remove them from under the machine and dispose of the mud accumulated.

A water pump can be installed inside the deposit to move the water.



IMPORTANT PARTS OF THE MACHINE

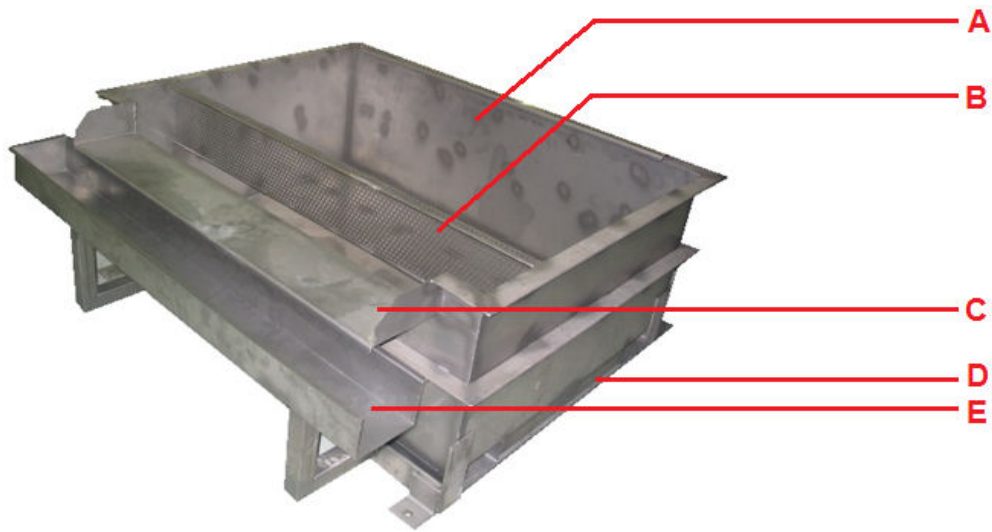

A: Stainless steel deposit.

B: Different size filters.

C: Water exit.

D: Deposit stand. Accessible with a fork lift truck.

E: Water exit flow.

TECHNICAL SPECIFICATIONS

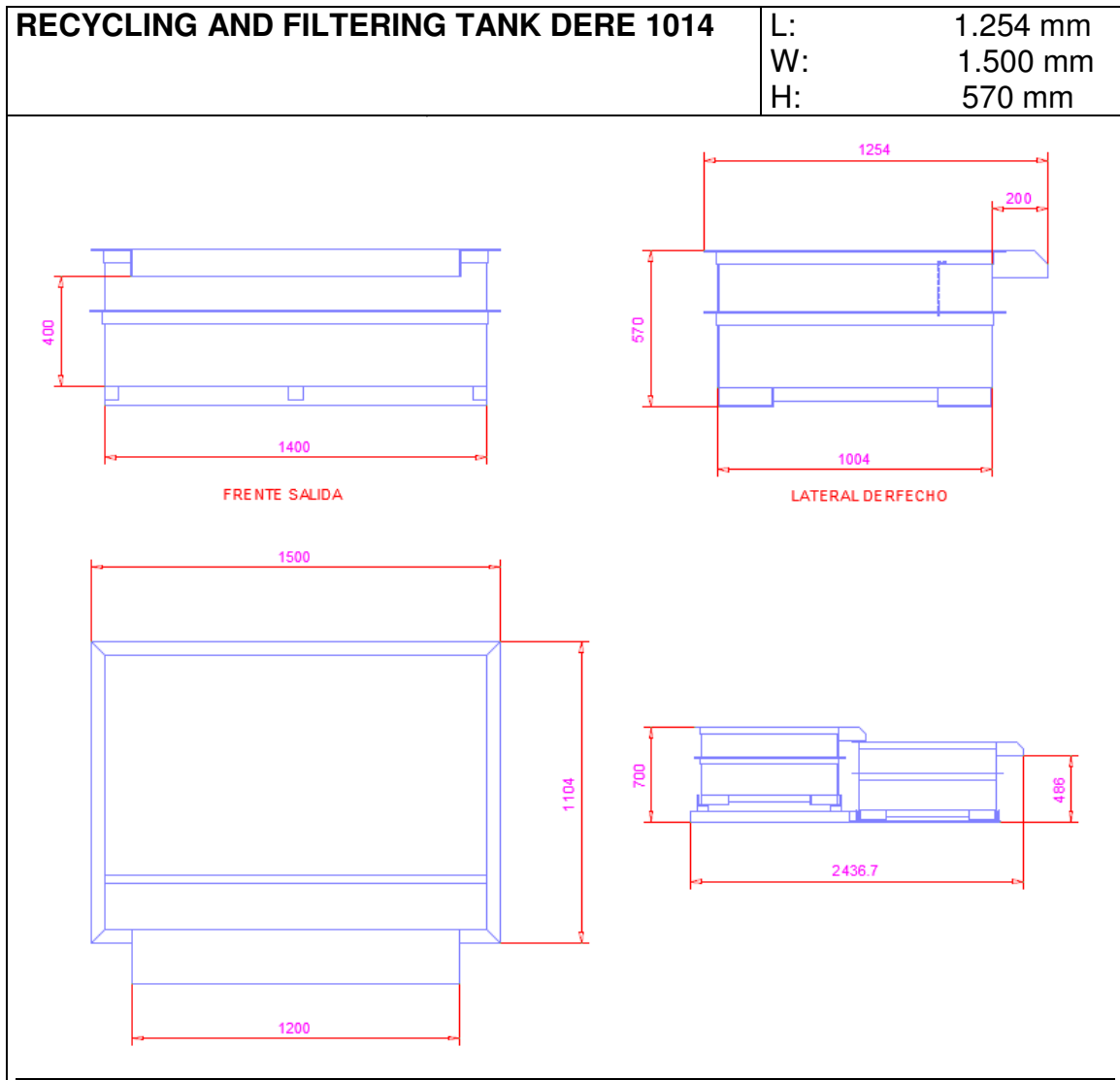

- No motors at all.
- Water deposit with a capacity of 1 m³.
- Capacity between 5 and 25 m³ per hour.
- Easily accessible with a fork lift truck.
- Normally, we would use two deposits in line, with a maximum of four.
- Very low maintenance.
- Weight: 200 Kg.
- CE Marking.

At **MARTIN MAQ** we know that you take great care of your product.

We know that this requires much effort and dedication. This is why we always place all our efforts in designing and manufacturing machines that will help you process your product efficiently, giving it the best possible finish.

We build all our machines to the highest of quality standards, making maintenance very easy and extending the machine's working life.

We have, at your disposal, an after-sales technical team that will assist you with any doubts that you may have during use and will inform you about how to care for your machine and keep maintenance as low as possible.

AFTER-SALES SERVICE

**ALWAYS REQUEST
ORIGINAL
MARTIN MAQ
SPARE PARTS**



I+D+I



FABRICACIÓN

**SERVICIO
POST VENTA**



REPUESTOS



MARTIN MAQ
Autovía A-601, Exit 91
40291 TABANERA LA LUENGA
Segovia (SPAIN)

T: +34-921-122 122
F: +34-921-57 70 88
e-mail: martinmaq@martinmaq.com
www.martinmaq.com

MARTIN MAQ Distributor:

